

**Actively Seeking New Service & Tire Center and Supercenter Locations  
4,000 to 5,000 sq ft & 14,000 to 16,000 sq ft Existing or Former Service Centers**

## **Richmond Area**

- Hull Street Road Super Store Site
- Broad Street near Boulevard
- Patterson Avenue near Parham Road
- Route 1 / North of Parham Road
- Mechanicsville East of I-295
- Chester
- Colonial Heights

## **Hampton Roads Area**

- Virginia Beach Blvd. / Pembroke  
First Colonial Road
- Battlefield Boulevard / Greenbrier
- Chesapeake Square / Churchland
- Norfolk / Little Creek Road
- York County / Route 17
- Newport News / Jefferson Ave.

## **Fredericksburg Area**

- Massaponax
- Route 17



Pep Boys has approximately 6,000 service bays within over 580 owned and leased locations in 35 states and Puerto Rico. Along with its fullservice vehicle maintenance and repair capabilities, the Company also serves the commercial auto parts delivery market and is one of the leading sellers of replacement tires in the United States. Customers can find the nearest location by calling 1-800-PEP-BOYS or by visiting [www.pepboys.com](http://www.pepboys.com).

The Service & Tire Center format serves the Do-It-For-Me segment of our customer base and will provide more convenient locations. The locations will be supported by our larger Supercenters which will typically be 5 to 20 minutes away.

The Supercenter format serves the Do-It-For-Me, Do-It-Yourself and Commercial segments of our business. These locations will be strategically placed in areas where growth opportunities exist.



**Sigma National, Inc**  
1213 Mall Drive  
Richmond, VA 23235  
(804) 423-5335  
[www.sigmanational.com](http://www.sigmanational.com)

**SUBMIT SITE INFORMATION TO  
EXCLUSIVE AGENT**  
Tred Spratley (804) 423-5335, x320  
[tredspratley@sigmanational.com](mailto:tredspratley@sigmanational.com)

## SERVICE & TIRE CENTER SITE

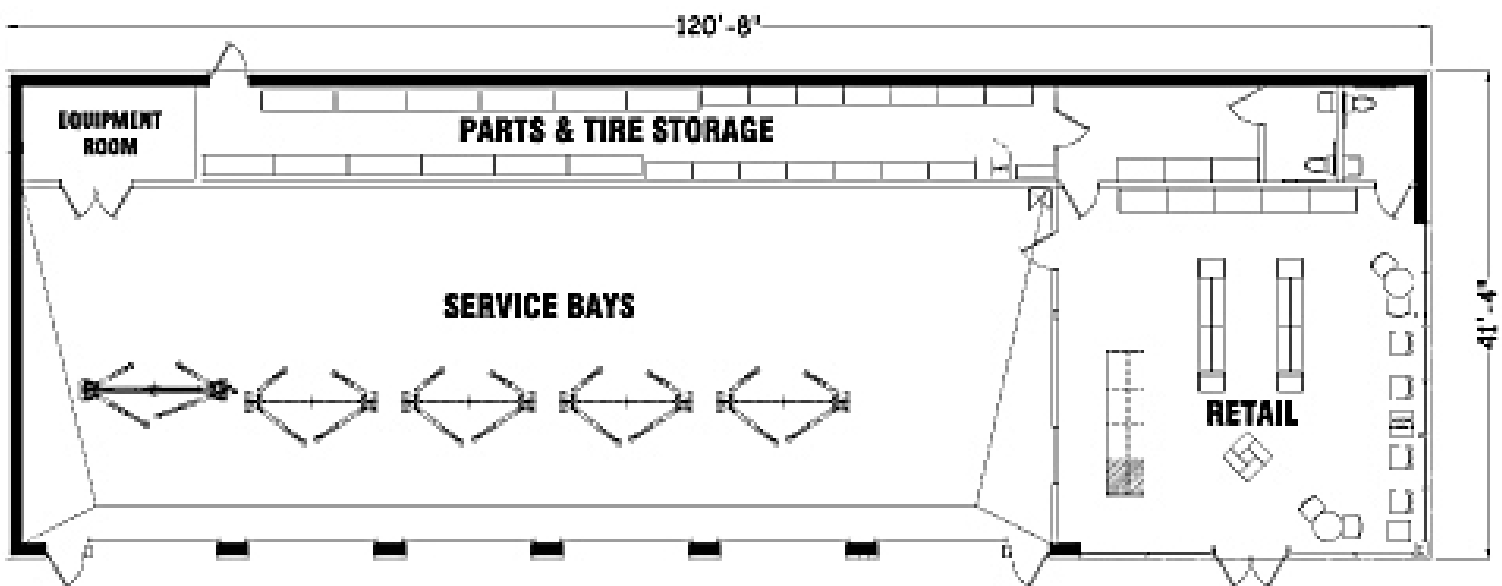

### **SERVICE & TIRE CENTER SITE CRITERIA**

- Existing buildings with 5 or more service bays.
- Will also consider conversion of existing retail facilities with ceiling heights of at least 13 feet and glass front.
- 15 or more parking spaces preferred.
- Site must be zoned for service and retail.
- Minimum traffic counts of 22,000 cars per day.
- Median household income of \$55k or higher.

## SUPERCENTER SITE



### SUPERCENTER SITE CRITERIA

- Existing buildings or retail space with ceiling heights of at least 13 feet.
- 14,000 to 16,000 square foot building.
- Can accommodate 6 to 8 Service Bays.
- Glass storefront preferred.
- 50 or more parking spaces preferred.
- Site must be zoned for service and retail.
- Minimum traffic counts of 35,000 cars per day.
- 100,000 people within Trade Area.
- Median household income of \$55k or higher.

